

TENSORES
Chain stretcher
Tendeur de chaîne

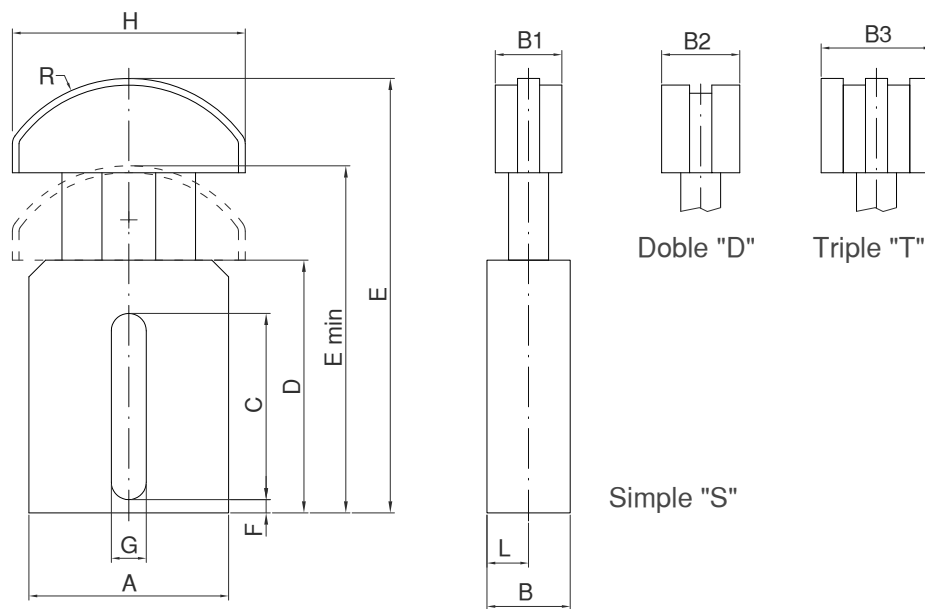

Paso Pitch Pas	Newton	A	B	C	D	E	E min	H	G	H	L	B1	B2	B3	R	Peso Weight Poids
3/8"	210	60	25	56	76	140	110	4	10,5	70	12,5	20	20	25	42	0,57
1/2"	210	60	25	56	76	140	110	4	10,5	70	12,5	20	20	35	42	0,57
5/8"	300	60	25	56	76	145	115	4	12,5	85	12,5	20	25	40	50	0,58
3/4"	300	60	25	56	76	145	115	4	12,5	85	12,5	20	30	49	50	0,58
1"	450	60	25	56	76	150	120	4	12,5	100	12,5	20	45	78	58	0,60
1" 1/4	450	60	25	56	76	150	120	4	12,5	100	12,5	20	54	90	58	0,60
1" 1/2	450	60	25	56	76	150	120	4	12,5	100	12,5	20	70	119	58	0,60